

# Blower Packages

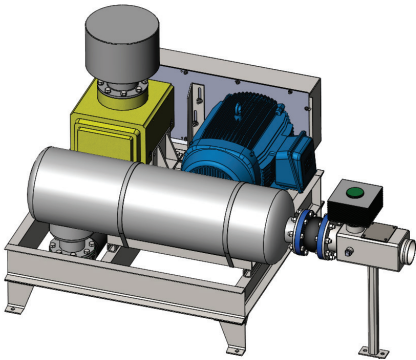

Cyclonaire's custom built pressure blower packages can be designed for a wide variety of applications: semi-dense phase conveying or PD style railcar/truck unloading, dilute-phase conveying, hopper, bin, silo aeration kits, and more.

Each blower package is engineered for your application's elevation and temperature.

**Wide Range of Sizes** - Our blower capacities can range from as little as 150 CFM to more than 3,000. Blower pressures up to 15 psig.

**Flexibility** - Built to accommodate your unloading needs, our packages can be integrated into existing systems, as well as new installations.

## Standard

Inlet filter silencer with filter service indicator; exhaust silencers; safety pressure relief valve; outlet check valve; OSHA belt guard protector; adjustable belt tension base; rigid channel iron frame designed to your specifications

## Standard Options

Temperature switches and transmitters; Pressure switches and transmitters; flanged connections; motor starters; sound enclosures

## Custom Options

Diesel or gas powered; custom colors/coatings



### Pressure Dilute Phase System

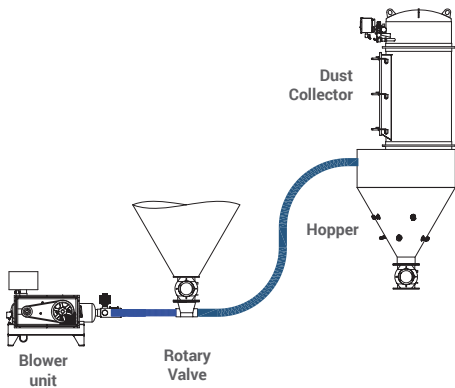

### Semi-Dense Phase System

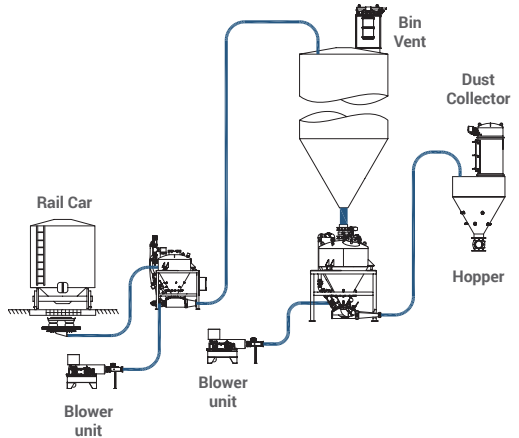

Contact [sales@cyclonaire.com](mailto:sales@cyclonaire.com).

**cyclonaire**  
pneumatic conveying solutions

(800) 445-0730 | [cyclonaire.com](http://cyclonaire.com)